

Overview



The CatLog-B is a GPS logger solution for medium and large sized animals/wildlife like sheep, cattle, cows, horses, deer, and reptiles. It is housed in a crush- and waterproof dry box. Even compact sized it can carry battery packs that power the device for months to years.

The device will record the position in an adjustable time interval. The movement profile can later be displayed on a map or exported to use with other software.

Optimized for scientific use, CatLog-B offers the following features:

- Two belt loops for easy attachment to belts, collars and harnesses
- Fiberglass reinforced plastic withstands tough conditions, seawater and UV light
- Optimized weight and operation time by scalable battery size

Specification

Device dimensions	150x 103x 54mm / 5.9 x 4 x 2.1 inch		
Device weight without battery	200 grams		
Battery	Rechargeable Lithium Polymer Packs		
	Capacity	Operation**	Weight
	2500mAh	400h	+50g
	** based on 30s capture interval, scales almost linear with interval time		
	Maximum capacity: 3 packs = 7500mAh		
Operation temperature	-20 to +60 degrees Celsius		
Activation	Magnetic switch		
GPS chipset	Sirf III		
GPS antenna	Patch 15x15x2mm		
Position accuracy	5-10m, depends on signal strength (position jitter is expected in low satellite signal reception conditions and power save mode)		
Position logging interval	Adjustable 1s - 60 minutes. Weekly scheduling mode available. 1-24 positions per day with customized activation circuit.		
Recorded data	Time, position, speed, altitude, direction		
Storage capacity	Up to 64000 positions		
Interface	USB1.1		
Operating system	Windows XP, Windows 2000, Windows 7, Windows 8		
Export data format	GPX, CSV (Excel)		

Specification is preliminary and can change without notice.

Power Consumption

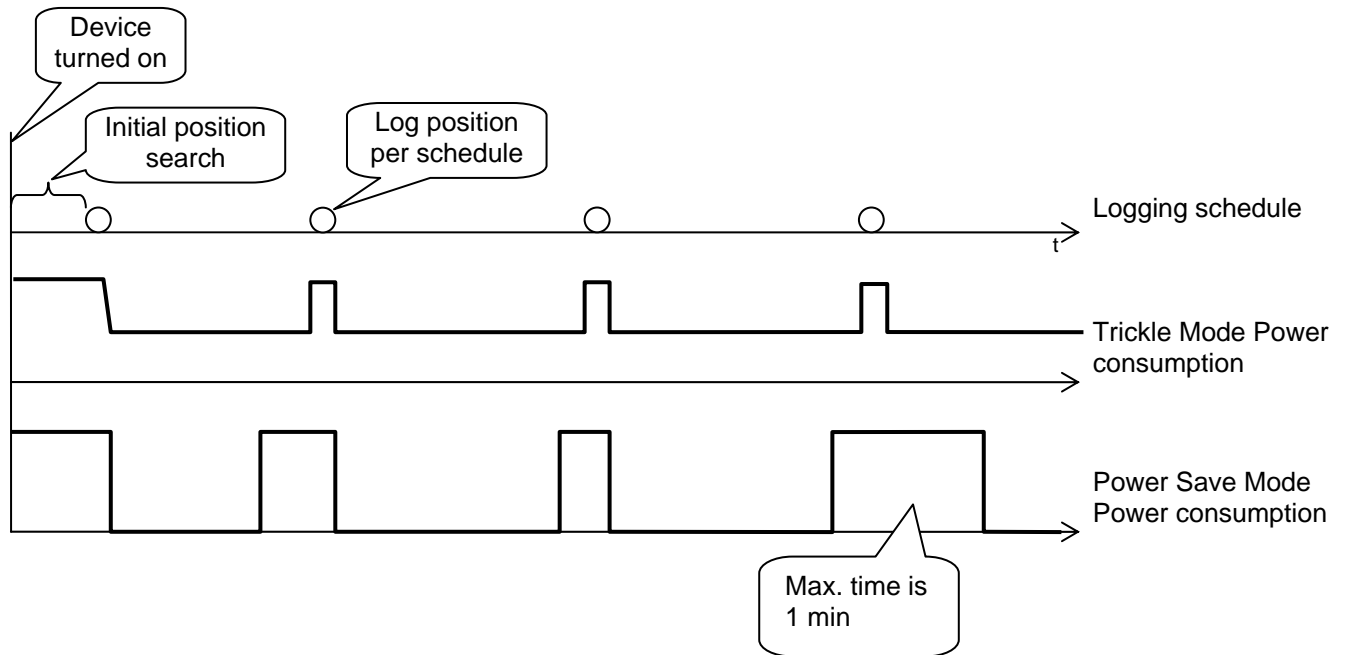

Trickle power is standard mode, it will continuously track satellites. Once it is time to record position it will be done quickly with good accuracy. The power consumption during standby time depends on the reception signal quality.

Power Save mode turns the GPS receiver off during standby time. Once the time comes to record a position it will turn on the GPS receiver, provide it with position data from the last position and enable the search engine. Since the receiver is not aware of changes in position and reception quality it may take significantly longer to get a position. The search engine is disabled after 1 minute in order to prevent battery drainage. May result in more inaccurate results.

Typical power consumption values:

Initial position search: 40mA, stopped after 5 minutes

Trickle power standby: 5-40mA

Trickle power logging: 40mA, 2 seconds

Power Save standby: 0.5mA

Power Save logging: 40mA, stopped after 1 minute

Recorded Positions vs. Battery Capacity

Assumptions: Power Save Mode, 30s interval

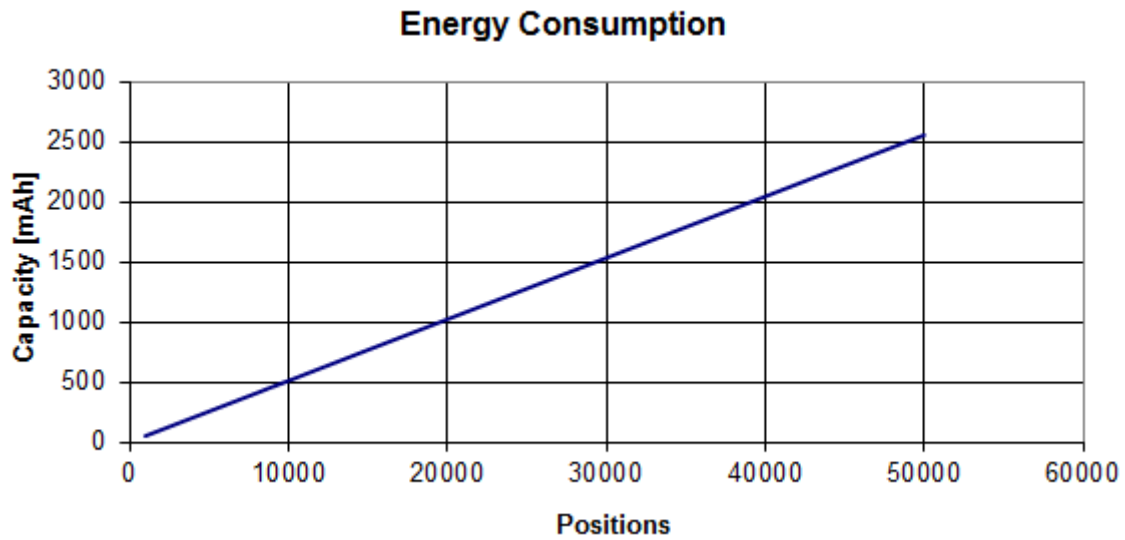

Recorded Positions vs. Interval Rate

Assumptions: Power Save Mode, 2500mAh battery

Interval (s)	Positions	Days
10	51000	6
30	49000	17
60	46000	32
120	41000	57
240	34000	94
480	26000	144
960	17000	189
1200	15000	208
1800	11000	229
3600	6000	250
7200	3200	267
14400	1650	275

Enclosure Drawings

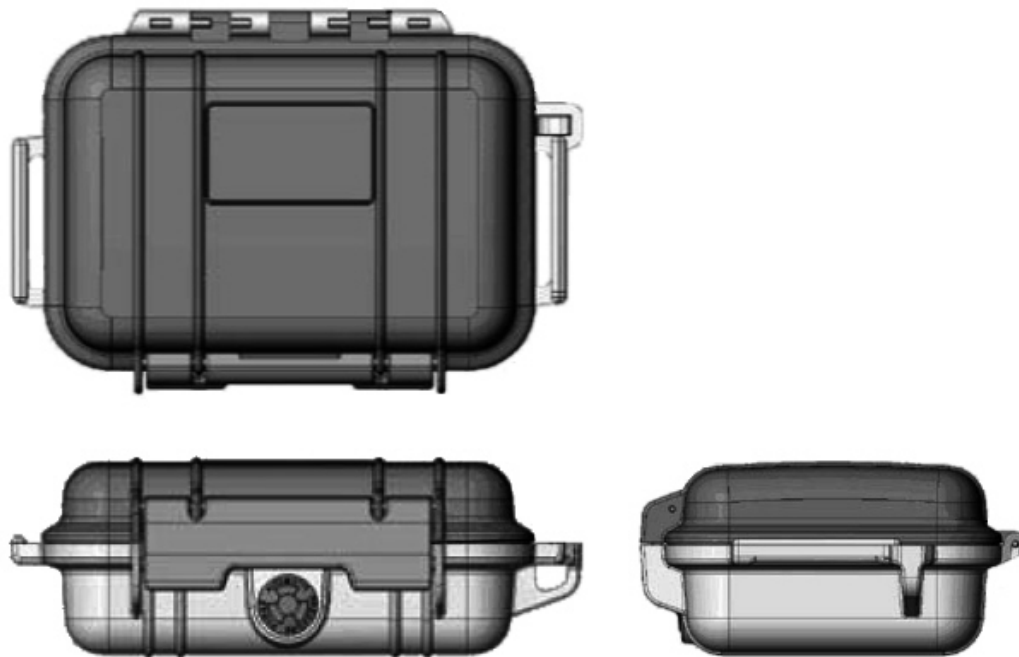

© 2011-2014 Catnip Technologies, Ltd.

Email: info@mr-lee.com

Web: www.mr-lee-.com

Not to be reproduced in whole or part for any purpose without written permission of Catnip Technologies, Ltd.

Information provided is believed to be accurate and reliable. These materials are provided by Catnip Technologies as a service to its customers and may be used for informational purposes only. Catnip Technologies assumes no responsibility for errors or omissions in these materials, nor for its use. Catnip Technologies reserves the right to change specification at any time without notice. These materials are provided "as is" without warranty of any kind, either expressed or implied, relating to sale and/or use of Catnip Technologies products including liability or warranties relating to fitness for a particular purpose, consequential or incidental damages, merchantability, or infringement of any patent, copyright or other intellectual property right.

Catnip Technologies further does not warrant the accuracy or completeness of the information, text, graphics or other items contained within these materials. Catnip Technologies shall not be liable for any special, indirect, incidental, or consequential damages, including without limitation, lost revenues or lost profits, which may result from the use of these materials.

Catnip Technologies products are not intended for use in medical, life-support devices, or applications involving potential risk of death, personal injury, or severe property damage in case of failure of the product.